



Publisher homepage: www.universepg.com, ISSN: 2663-7820 (Online) & 2663-7812 (Print)

<https://doi.org/10.34104/cjbis.022.01370143>

Canadian Journal of Business and Information Studies

Journal homepage: <http://www.universepg.com/journal/cjbis>

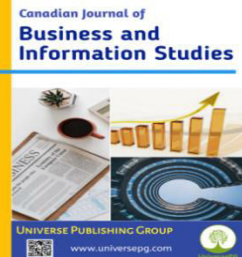

Evaluating the Prediction Accuracy of MACD and RSI for Different Stocks in Terms of Standard Market Suggestions

Hasan M Sami^{1*}, Kazi Ayman Ahshan², Pedrus Niloy Rozario², and Nusaiba Ashrafi²

¹Department of Accounting & Finance, North South University, Dhaka, Bangladesh; and ²School of Business, Canadian University of Bangladesh, Dhaka, Bangladesh.

*Correspondence: hasan.sami@northsouth.edu (Hasan M Sami, Lecturer, Department of Accounting & Finance, North South University, Dhaka, Bangladesh).

Received Date: 21 November 2022 Accepted Date: 24 December 2022 Published Date: 31 December 2022

ABSTRACT

Technical Indicators make an important aspect of the selection of stocks on the NYSE. Using standard suggestions provided by MACD and RSI has been capable of identifying nearly 56% of growing stocks during a distressed market. In this research, we have used the same technical parameters used in major stock exchanges (SE) in the whole world and observed their application in many locally proficient stocks of various countries. The research target will be able to generate the effectivity of MACD & RSI as a technical predictor for high-quality stocks from different stock exchanges (SE) to understand the capability of MACD & RSI in terms of standard parameters for predicting stock price directions. We have observed that nearly 26 stocks from 7 different markets have been able to make correct predictions of stock price directions with 56% on MACD and 81% on RSI. Thus, it is considered that MACD & RSI are qualified approaches for making stock price predictions for these stocks.

Keywords: MACD, RSI, Train test split, Market benchmark, Stock representation, and Price direction.

INTRODUCTION:

Since the founding of significant financial operations worldwide, technical finance has played a significant role in asset investment. In an attempt to anticipate the future prices of any asset, a variety of technical characteristics have been applied. Vezeris *et al.* have tested that MACD is a standard strategy that has been successfully implemented in the pricing processes of many volatile asset classes like FOREX, metal and energy, and cryptocurrencies with a certain change in boundary line operations (Vezeris *et al.*, 2018). Rosillo contradicted the pattern of selection of assets within the standard boundary frameworks of ACD in terms of standard time practice as the best alternative for the selection of assets (Alam, 2020; Rosillo *et al.*, 2013).

Generally, such usage of the standard MACD framework makes small investors interested in the finan-

cial markets which conceivably can be a better alternative for asset price gain according to Rosillo. Aguirre *et al.* suggest that using technical analysis parameters with artificial intelligence as the background for practicing the MACD benchmark is considered an important approach for selecting assets, which might be valuable for portfolio performance development (Aguirre *et al.*, 2021).

Although we know using LSTM as an important time series forecasting parameter, we have made significant progress through an RNN-based feed-forward neural network whereas in NYSE we have created a portfolio successfully (Sami and Arifuz-zaman, 2021). Similarly, in much smaller stock exchanges like DSE, we have qualified progress to create a successful portfolio using LSTM as the time series forecasting process to predict future asset prices (HM Sami *et al.*, 2021). In this research, ac-

According to scholarly suggestions, we will incorporate standard boundaries and practices of MACD which will practice the EMA valuations of 26 Day average with 12 Day average as the boundary for prediction and observe how these assets from different financial backgrounds will be able to predict future stock price directions as a standard suggestion for considering MACD an important policy for technical finance indication. The importance of RSI as a financial indicator is explained by Rudik in terms of volumetric analysis of either being oversold or over-bought through technical parameters (Rudik N.I., 2013). Hill *et al.* have found that RSI has successfully foretold whether the houses are being over-bought or over-sold and have been aligned with the price increase and decrease (Hill *et al.*, 1997). Yang & Zhou have shown that investor behavior is aligned with purchase decisions hence RSI plays an important role in overbuying or overselling assets in terms of investment purposes (Yang & Zhou, 2015). Within the parameters of understanding human behavior RSI shows the practical evidence of how people react to new factors to make investments into assets within the fact of financial benchmarks as explained through RSI by (Neuhann *et al.*, 2020). Wheatley showed that RSI with applied implications on financial modeling can develop a qualified portfolio that can be highly returning (Wheatley, 1989). Hence, we are going to evaluate RSI within the standard market parameters which will be useful for understanding if all the undertaken assets can be qualified enough to make correct suggestions relating to their price proceedings by overbuying or oversell signals.

In this study, we've taken on equities from multiple SEs (Stock Exchanges), each of which has a unique market denomination and signal for a specific period of time. We will assess if the MACD and RSI standard parameters that have been put to the test will be able to provide suitable indications for the buying and selling of stocks based on standard parameters.

Literature Review

Zida mentions that in the case of highly volatile investments like FOREX, and MACD with proper parameters of 26 Day EMA and 12 Day EMA proper predictions of increase or decrease could have been anticipated (Zida, 2013). Anghel mentions that MACD parameters within the standard market parameters have defined the prediction of stock price increases with high accuracy for stocks with standard

parameters throughout the world (Anghel G.D.I, 2015). Appel also suggested that MACD within the standard boundary parameters can predict the direction of price movement accordingly (Appel G, 2003). Our research thus emphasizes the standard boundary steps of the research paper within the perspective of price movement prediction by which we will check if MACD general parameters can be a qualified bench-mark for price direction. Chong *et al.* have observed how accurately the RSI indexing process has shown the similarity of human behavior and purchase pattern concerning investments that led to over-buying or overselling of assets (Chong *et al.*, 2008). Chong *et al.* further revisited the LSE (London Stock Exchange) and found that for different industries the RSI indexing needs to be changed to get better insights regarding the performance within the parallel pattern of investors' purchase or sell decisions (Chong *et al.*, 2014).

Kunt *et al.* have found in the case of evaluating a standing financial theory that stands with the benchmark performances of major stocks of any market, needs to be tested against any stocks of any market in order for that theory to be called universal (Kunt *et al.*, 1996). Jong *et al.* have found that a standing financial theory needs to be tested against the benchmark standpoints of variant market situations in order for the theory to have strong validity (Jong *et al.*, 2006). Jong also found that if the standing theory relates with investor perspective with the benchmarks of financial theories, then with a greater correlation the theory gets established. Such as the HR perspective of better employee motivation increased relevant experience and skillsets were tested against valid qualification points that were well justified to prove the standing theory (HM Sami, 2021).

Similarly, for financial asset selection, the way financial ratios play a key role similar to technical indicators can play a key role in portfolio development and management (HM Sami, 2021). Hence, according to various literature reviews, we have reached a conclusion to evaluate stock performance based on technical indicators like MACD and RSI. Our standard market predominant knowledge about MACD and RSI will be tested against various markets with differing volatility and index parameters. The following theoretical background hence will support the financial position of investment into stocks by technical indicators

Theoretical Background

Moving Average Convergence and Divergence (MACD)

MACD has been in use as an important technical parameter for understanding future prospective asset price direction. MACD is an indicator that follows the trend momentum, depicting a relation between two moving averages of a security's price. The calculation of MACD is carried forward by deducting the 26-period EMA (Exponential Moving Average) from the 12-period EMA.

RSI (Relative Strength Index)

The Relative Strength Index (RSI) is an impulse indicator that assesses the magnitude of recent price swings to determine if an asset is overbought or oversold. RSI values of 70 or higher are traditionally interpreted and used to indicate that the investment has become overbought or costly and is due for a trend reversal or corrective price decrease. Market circumstances that are oversold or undervalued are indicated by an RSI level of 30 or less. Overbought refers to when the market value of an asset exceeds its fair or intrinsic value. Overbought assets typically reflect recent or short-term price changes. As a result, the market is projected to experience a price correction in near future. Overbought assets are frequently considered sellable. However, depending on whom you ask, the meaning of oversold varies. Fundamental traders feel an asset has been oversold when its price falls below its fair or intrinsic worth. As a result, they trade for less than their perceived worth. In market research and trading signals, the RSI is considered a bullish indication when it rises over the horizontal 30 reference level. On the other hand, an RSI that goes below the horizontal 70 reference level is considered a bearish indicator. Because some assets are more volatile and move more quickly than others, figures 80 and 20 are frequently used to signify whether an asset has been overbought or oversold.

EMA (Exponential Moving Average)

$$EMA_{Today} = \left(Value_{Today} * \left(\frac{Smoothing}{1 + Days} \right) \right) + EMA_{Yesterday} * \left(1 - \left(\frac{Smoothing}{1 + Days} \right) \right)$$

Fig. 1: EMA Formula.

Exponential Moving Average (EMA)

The exponential moving average (EMA) is a type of moving average (MA) that lends greater weight and significance to the most recent data points. The exponential moving average is also known as the exponentially weighted moving average (EWMA).

RSI Indicator

$$RSI_{1st\ Step} = 100 - 100 / (1 + (Average\ Gain / Average\ Loss))$$

Standard Market RSI 14 Days

So,

$$RSI_{average\ gain} = (Previous\ Average\ Gain \times 13) + Average\ Gain\ in\ 1^{st}\ Step$$

$$RSI_{average\ loss} = (Previous\ Average\ Loss \times 13) + Average\ Loss\ in\ 1^{st}\ Step$$

$$RSI_{next\ step} = 100 - 100 / (1 + RSI_{average\ gain} / RSI_{average\ loss})$$

Smoothing Constant

12 Days SC = 2 / (12 + 1)

26 Days SC = 2 / (26 + 1)

Fig. 2: Computation of RSI.

An exponentially weighted moving average (EWMA) reacts more strongly to recent price fluctuations than a simple moving average (SMA), which assigns equal weight to all the observations in the period.

In general, the smoothing constants used to compute the EMA for 12 and 26 days are based on 12 and 26. Furthermore, the primary selection of asset prices will be based on the SMA (simple moving average) for the first day, and the EMA's will be computed using asset values from the following day forward.

MACD Indicator

$$X_{12} = 12\ Day\ EMA$$

$$X_{26} = 26\ Day\ EMA$$

For i in range (1st Asset, Last Asset):

if $X_{12}(i) - X_{26}(i) = Positive$

Bullish Price Movement Indication

else if $X_{12}(i) - X_{26}(i) = Negative$

Bearish Price Movement Indication

Return all assets price direction

Fig. 3: MACD Computation.

METHODOLOGY:

Considering the various markets which have been considered for sample tests, we have included stocks of standard markets like the Bombay Stock Exchange (BSE), Tokyo Stock Exchange, Hongkong

Stock Exchange (HKSE), and also much-localized stock exchanges like Dhaka Stock Exchange (DSE), Indonesia, Malaysia, and Thailand. Our research target is to observe if the standard MACD and RSI can be giving good stock movement directions. The research process has accumulated a sample of 27 different stocks, all of which are well-inclined with market performances and well-known locally or internationally in terms of market capitalization. Hence this research will include stocks that behave similarly to the market as we have performed RSI and MACD for the SE of these markets as well to show if the market is supposed to move up or down based on index movements through standard MACD & RSI measurement.

Hence, we will start our research process with the following steps:

- a) MACD of all Sample SE
- b) RSI of all Sample SE
- c) MACD of all Sample Stocks
- d) RSI of all Sample Stocks
- e) Accuracy Measurement in terms of Price Direction for SE and Stocks in respective SE.
- f) Correlation Analysis in terms of the Price Movement of SE and Price Movement of Respective SE stock
- g) Accuracy tests between Actual prices of the Testing period and predicted Stock Price Movement Direction
- h) MACD & RSI correlation draw in terms of Price movement indication

A further illustration of the research methodology is given below:

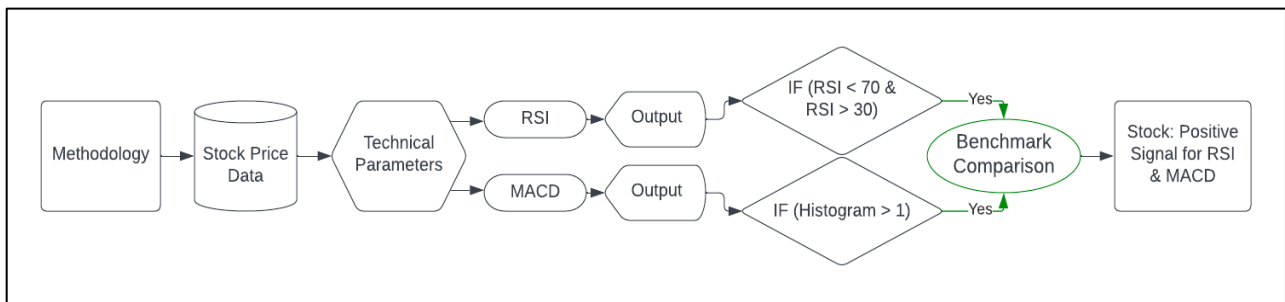

Fig. 4: Research Methodology Illustration.

RESULTS:

Table 1: Findings from the MACD & RSI Stock dataset and its results.

Markets Index	STOCKS	MACD	RSI	COMBINED
DSEx	BDCOM	YES	YES	YES
	BEXIMCO	YES	YES	YES
	ORIONPHARM	NO	YES	NO
	AAMRATECH	YES	YES	YES
SENSEx	DIVISLAB.BO	NO	YES	NO
	LTI.BO	YES	NO	NO
	SUNPHARMA.BO	NO	YES	NO
	TCS.BO	NO	YES	NO
HSI	2196.HK	NO	YES	NO
	2269.HK	YES	NO	NO
	0182.HK	NO	YES	NO
JKSE	MERK.JK	YES	YES	YES
	SIDO.JK	YES	YES	YES
	EERA.JK	NO	NO	YES
NIKKEI	ALMPY.TK	NO	YES	NO
	CHCGF.TK	NO	YES	NO
	DSNKY.TK	YES	NO	NO
	TAK.TK	NO	YES	NO
KLCI	KOTRA.KL	YES	YES	YES

	AHEALTH.KL	NO	YES	NO
	INARI.KL	YES	YES	YES
SET	JMART.BK	YES	YES	YES
	SKR.BK	YES	YES	YES
	KCE.BK	YES	NO	NO
	VIH.BK	NO	YES	NO
	SYNEX.BK	YES	YES	YES

RSI findings based on the market indexes

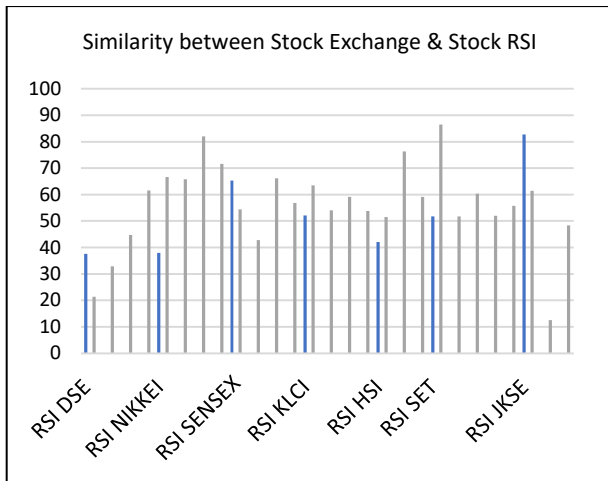

Graph 1: Similarity test of Stock Exchange and individual Stock

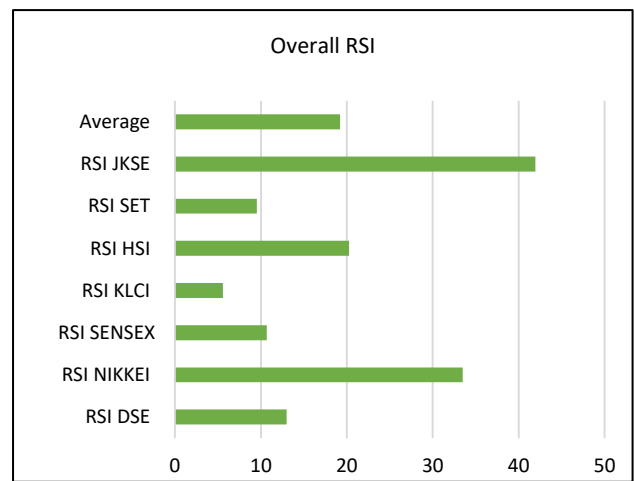

Graph 2: RSI results of Market Index.

Considering the market volatility and responses of each stock in reference to the market performances we have found that DSE, SENSEX, KLCI, and SET possess the best possible similarity in terms of market response and stock performances. Although other stocks didn't make a good amount of similarity hence the overall accuracy possession generated is 19.54 which is just somehow smaller than 20 giving a very small margin for being considered accurate in terms of considering RSI to be an overall accurate measurement for Stock price movement. It is observed that some stocks behave the same way as the SE (Stock Exchange) movements are observed. Whereas there are some stocks although being an important part of market representation do not behave in an exactly similar manner. All these stocks are examined and explained with their respective market performance similarity. It's seen that the stocks which represent their respective SEs have a very low difference in terms of price direction whereas stocks with a high difference in SE and Stock price movement are highly distinguished in terms of price movement and performance rather than their respective SE. In summation, although RSI stands for similarity, it is very weakly suggesting the market similarity with the Stock's price direction similarity.

MACD & RSI Findings of Stocks

MACD

The training and testing dataset split has created a specific boundary that supports the market performance regarding major representative stocks. It's seen that MACD as a technical parameter has suggested nearly 56% of Stocks to have gained in price and among all the suggested gaining prices during the testing period each has gained prices. Whereas the suggestions about the rest of the 44% stocks were unable to provide accuracy for a short-term profit. Therefore, MACD has suggestions rather than RSI in terms of prediction of price movements.

RSI

The stocks have also shown a similarity of more than 50% indication based on RSI in terms of purchase decisions. 84% of stocks have made better stock purchase decisions whereas only 16% of stocks made decisions not according to RSI technical indication.

Drawbacks & Further Research

This research was carried out within the framework of exact market suggestions for MACD and RSI both of which with primary notifications could not have carried out better predictions despite industrial data suggestions.

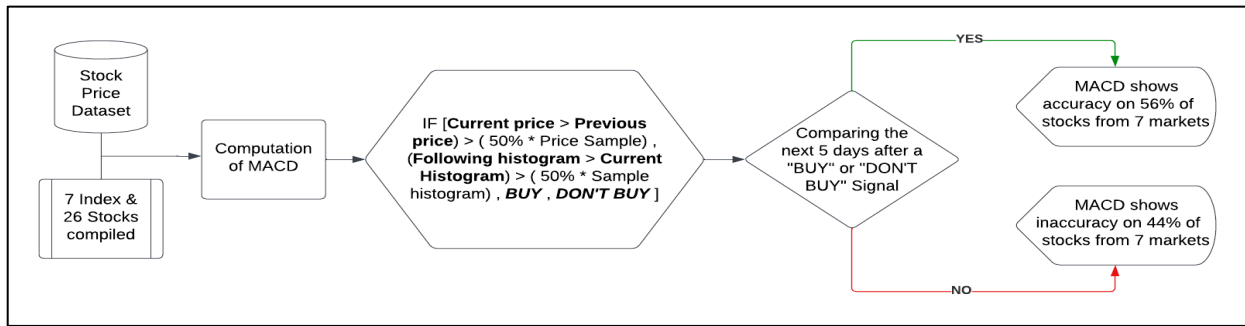

Fig. 5: Illustrating the computation of MACD accuracy testing.

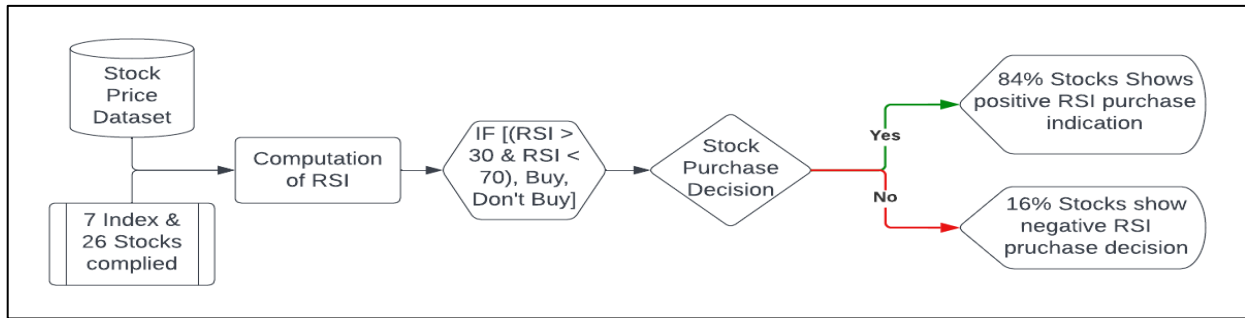

Fig. 6: Illustrating the computation of RSI accuracy testing.

Similarly, all the predictions were not expected within the framework of financial behavior due to stagnant volumetric changes in markets like JKSE, HSI, and Nikkei but they were specifically suggested under statistical notions rather than asset-affiliated accounting ratios. Hence the research focused more-over on a technical finance basis rather than a fundamental analysis. In order to make the research process much more effective, the MACD & RSI needs to be modified within the parameters of many affiliated finance-based suggestions.

CONCLUSION:

We can conclude that both MACD and RSI are reliable technical indicators for equities regardless of markets because the average for RSI-based finds was above 50% and the average for MACD-based findings was close to 78%. In general, market conditions produce financial perspectives that meet SE criteria, but stocks were unable to make the right predictions with more precision because there was not a much deeper dive into stock-based research. We have seen that in every stock index, there are some stocks that do not have big market capitalization and some stocks that have big market capitalization have observed that both MACD and RSI provide a quality signal in terms of purchase decision in case of a stock which holds big market capitalization. Hence, stocks of big trade volume are standardized for technical indication

ACKNOWLEDGMENT:

Acknowledgment is given to the sources of our asset information. The online database of Yahoo Finance, Simply Wall St., and Investing has helped to a large extent to acquire knowledge and choose the right dataset. The scholarly writings, research articles, and blogs that helped in writing this present paper are duly referred in relevant places of this article as well as in the reference list below.

CONFLICTS OF INTEREST:

All authors declare no conflict of interest with the contents of this research work.

REFERENCES:

- 1) Agudelo A, A.A., Duque M, N.D. and Rojas M, R.A. (2021), "Artificial intelligence applied to investment in variable income through the MACD (moving average convergence/ divergence) indicator", *J. of Economics, Finance & Administrative Science*, **26**(52), pp. 268 - 281. <https://doi.org/10.1108/JEFAS-06-2020-0203>
- 2) Alam QN. (2020). Impacts of macroeconomic variables on the stock market returns of South Asian region, *Can. J. Bus. Inf. Stud.*, **2**(2), 24-34. <https://doi.org/10.34104/cjbis.020.24034>
- 3) Anghel, G. D. I. (2015). Stock Market Efficiency and the MACD. Evidence from Countries around the World. *Procedia Economics and Finance*, **32**, 1414 - 1431. [https://doi.org/10.1016/s2212-5671\(15\)01518-x](https://doi.org/10.1016/s2212-5671(15)01518-x)

- 4) Appel, G. (2003). Become Your Own Technical Analyst. *The J. of Wealth Mana*, **6**(1), 27 - 36. <https://doi.org/10.3905/jwm.2003.320471>
- 5) Chong, T. T.-L., & Ng, W.-K. (2008). Technical analysis and the London stock exchange: testing the MACD and RSI rules using the FT30. *Applied Economics Letters*, **15**(14), 1111-1114. <https://doi.org/10.1080/13504850600993598>
- 6) Chong, T., Ng, W.-K., & Liew, V. (2014). Revisiting the Performance of MACD and RSI Oscillators. *J. of Risk and Financial Management*, **7**(1), 1 - 12. <https://doi.org/10.3390/jrfm7010001>
- 7) Demircuc - Kunt, A., & Maksimovic, V. (1996). Stock Market Development and Financing Choices of Firms. *The World Bank Economic Review*, **10**(2), 341 - 369. <https://doi.org/10.1093/wber/10.2.341>
- 8) Habibilashkary, Ziba. (2013). Technical analysis of Forex by MACD Indicator. *Inter. J. of Humanities & Management Sciences (IJHMS)*, **1**, 2320-4044.
- 9) Hill, R. C., Knight, J. R., & Sirmans, C. F. (1997). Estimating Capital Asset Price Indexes. *Review of Economics and Statistics*, **79**(2), 226 - 233. <https://doi.org/10.1162/003465397556818>
- 10) Jong, C. de, Koedijk, K. G., & Schnitzlein, C. R. (2006). Stock Market Quality in the Presence of a Traded Option. *The J. of Business*, **79**(4), 2243-2274. <https://doi.org/10.1086/503662>
- 11) Neuhann, Daniel and Sockin, Michael, Investment in Concentrated Financial Markets: A Strategic Q-Theory, November 1, 2020. <http://dx.doi.org/10.2139/ssrn.3320035>
- 12) Rosillo, R., de la Fuente, D., & Brugos, J. A. L. (2013). Technical analysis and the Spanish stock exchange: testing the RSI, MACD, momentum, and stochastic rules using Spanish market companies. *Appl Eco.*, **45**(12), 1541-1550. <https://doi.org/10.1080/00036846.2011.631894>
- 13) Rudik, N.I. (2013), "The Encyclopedia of the Indicator RSI (Relative Strength Index)", *Corporate Governance*, **13**(2), pp. 218-219. <https://doi.org/10.1108/14720701311316698>
- 14) Sami HM, and Arifuzzaman SM. (2021). Comparing pure stock portfolio with stock and crypto-currency mixed portfolio through LSTM to compare and analyze investment opportunities for portfolio performance measurement, *Aust. J. Eng. Innov. Technol.*, **3**(3), 45-56. <https://doi.org/10.34104/ajeit.021.045056>
- 15) Sami HM, Fardous L, and Ruhit DS. (2021). Portfolio optimization in DSE using financial indicators, LSTM & PyportfolioOpt, *Int. J. Mat. Math. Sci.*, **3**(4), 74-84. <https://doi.org/10.34104/ijmms.021.074084>
- 16) Sami HM. (2021). Optimizing organizational overall performance, the use of quantitative choice of HR in carrier quarter enterprise of Bangladesh, *Can. J. Bus. Inf. Stud.*, **3**(3), 49-59. <https://doi.org/10.34104/cjbis.021.049059>
- 17) Sami HM. (2021). Portfolio construction using financial ratio indicators and classification through machine learning, *Int. J. Manag. Account.* **3**(4), 83 - 90. <https://doi.org/10.34104/ijma.021.083090>
- 18) Vezeris, D., Kyrgos, T., & Schinas, C. (2018). Take Profit and Stop Loss Trading Strategies Comparison in Combination with a MACD Trading System. *J. of Risk and Financial Management*, **11**(3), 56. <https://doi.org/10.3390/jrfm11030056>
- 19) Wheatley, S. M. (1989). A critique of latent variable tests of asset pricing models. *J. of Financial Economics*, **23**(2), 325 - 338. [https://doi.org/10.1016/0304-405x\(89\)90061-5](https://doi.org/10.1016/0304-405x(89)90061-5)
- 20) Yang, C., & Zhou, L. (2015). Investor trading behavior, investor sentiment, and asset prices. *The North American J. of Economics and Finance*, **34**, 42-62. <https://doi.org/10.1016/j.najef.2015.08.003>

Citation: Sami HM, Ahshan KA, Rozario PN, and Ashrafi N. (2022). Evaluating the prediction accuracy of MACD & RSI for different stocks in terms of standard market suggestions, *Can. J. Bus. Inf. Stud.*, **4**(6), 137-143. <https://doi.org/10.34104/cjbis.022.01370143> 